

Machine Shop Orientation and Safety Training



Machine Shop Rules

1. **Safety glasses must be worn at all times.**
2. **Proper attire must be worn at all times.** (Loose or dangling clothing, hair, or jewelry and open-toed shoes are not allowed.)
3. **Students must complete orientation and safety training before they will be allowed in the Machine Shop**
4. **Students may not work alone in the Machine Shop.**
5. **Students may only use machines and power tools for which they have received training.**
6. **Absolutely, positively no horseplay is allowed in the Machine Shop.**
7. **Students have access to the Machine Shop Monday through Friday from 8:30am to 4:30pm.**
8. **Students may only use the Machine Shop to work on projects related to courses they are taking at Trinity College.**
9. **Students may not take tools out of the Machine Shop without the permission of the department Technician.**
10. **Students must clean up any mess they make and put away any tools they use before they leave the Machine Shop.**
11. **The compressed air hose may not be used to blow chips from a work piece or during the cleaning process.**
12. **Machine Shop doors must remain closed at all times.**
13. **Food and beverages are not allowed in the Machine Shop.**
14. **Students failing to comply with these rules will lose the *PRIVILEGE* of using the Machine Shop.**

Training Overview:

Machine Shop Orientation and Safety Training is intended to:

- Familiarize students with the Machine Shop and its resources
- Introduce students to the machines and power tools they are most likely to use, the:
 1. horizontal band saw
 2. vertical band saw
 3. drill press
 4. corded power hand drill
 5. bench grinder
 6. belt and disc sander
 7. Bridgeport vertical milling machine
- Demonstrate how to use those machines and power tools safely
- Give students hands-on experience in operating those machines and power tools safely

Students may only use machines and power tools for which they have received training!

- Students wishing to use other machines and power tools present in the Machine Shop must first schedule additional training with the department Technician.

Safety First!!!

The most important to remember when working with machines and tools of any kind is ***Safety first!***

Accidents happen quickly, and they can result in serious injury and even death.

That is why it is absolutely essential that anyone using machines and power tools respects all that they can do: both the good and the bad.

So remember, whenever you are in the Machine Shop, your primary focus should always be:

Safety first!

Best Practices for Safety

- **Do not rush** – Always work in a slow, thoughtful, and careful manner.
- **Always maintain your balance** – Physically, that means maintain an athletic, well balanced stance that allows you to react quickly. Mentally, that means never work in the Machine Shop when you are angry, upset, or distracted.
- **Keep the shop clean** – It reduces the chances of accidents occurring.
- **Beware of coolants or lubricants spilled or dripped on the floor** – If you see any, clean them up...whether you did it or not.
- **Use brushes to clear chips (not your fingers)**
- **Never leave a running machine**
- **If anything unusual happens – e.g. weird sounds, weird smells, weird events – turn off the machine immediately and find the department Technician or your instructor**
- **If you do not remember or do not know how to do something, ask the department Technician** – Never hesitate to ask a question. I want you to be safe, and I want you to be successful. **SO, IF YOU HAVE QUESTIONS, PLEASE ASK.**

If an Accident Occurs in the Machine Shop

If an accident occurs in the Machine Shop, a First Aid Kit, fire extinguisher, and campus telephone are located to the left of doors as you leave the room.

In the event of an emergency, call Campus Safety at x2222.

Students are required to report all accidents and near-misses to the department Technician and their instructor.

A Quick Tour of the Machine Shop

Machines and Workbenches

To be discussed during the hands-on portion of this training.

Grey Tool Cabinet, Shelves and Toolboxes

The grey tool cabinet contains measuring instruments, accessories and tools used with the Bridgeport vertical milling machine, the corded power hand drill, drill bits, tap and die sets, and other miscellaneous items.

The shelves next to the grey tool cabinet contain tools and accessories used with the lathe, fasteners, cutting fluids, lubricants, and other miscellaneous items.

The black rolling tool box, the brown tool box, and the blue rolling cabinet contain various hand tools.

Measuring Stone

The measuring stone stored on the workbench in the far rear corner by the wall is a precise (and expensive) measuring tool. It is only to be used with the Vernier Height Gage for the purpose of making precise measurements. ***When it is not in use, it must be covered and stored in the far back corner of the workbench. Do not stack things on it.***

Waste Cans

Three waste disposal bins are located under the workbench by the door:

- gray metal trash can – for **solid pieces** of scrap metal **only**
- red, lidded waste can – for rags used to clean up oil and other flammable items **only**
- yellow trash can – for everything else, including metal shavings

Ear Plugs and Hand Soap

Disposable ear plugs are available for student use and may be found with the safety glasses. If you decide to wear ear plugs, it is suggested that you put them in when you first enter the shop, before your fingers get dirty or oily.

Gojo Natural Orange Pumice Hand Cleaner is available for student use and may be found on the sink in the ME Lab (MCEC 19).

Clean up

Before leaving the Machine Shop, students are **required** to put away all of the tools they have used and to clean up any mess they have made. Brooms and dust pans have been provided for this purpose.

Students who do not clean up after themselves will lose Machine Shop privileges.

General Information

(Portions of the material in this section were taken from *Introduction to the Trinity Engineering Machine Shop* by Professor J. Palladino (September 2007).)

What is “Machining”?

Machining is the process of separating the “work piece” (the part you want to produce) from the “chips” (the unwanted material surrounding the part you want to produce). This requires:

- A securely held, sharp tool
- A securely held work piece
- Sufficient force applied to the tool to produce chip separation
- The continuous removal of newly formed chips (allowing the formation of subsequent chips)
- The prevention of overheating of the tool and / or work piece

Coolants and Lubricants

Cutting tools and work pieces will heat up during machining. Coolants, such as the Kool Mist used with the Bridgeport vertical milling machine and Dayton horizontal band saw, reduce heat build-up by flowing over the surfaces of the cutting tool and work piece, picking up some of their heat, and carrying it away.

Lubricants – such as Kool Mist, Relton A-9 Aluminum Cutting Fluid, and Rapid Tap Heavy Duty Cutting Fluid – reduce friction and clear space for the formation of new chips. They do so by lubricating newly formed chips, allowing them to slide away more efficiently and by flushing out chips that tend to stick in confined spaces.

Use of coolants and lubricants prolongs tool life, improves results, and allows faster cutting speeds.

A Word on Metal Selection

Use the type of metal your design requires. However, if your design does not specify a specific type of metal, it is suggested that students consider using aluminum. Aluminum is lighter, easier to work, and easier on the machines than steel or iron.

Useful, Non-Powered Tools in the Machine Shop

Measuring tools:

- Tape measure, yard sticks, and rulers
- 6-inch Machinist’s Rule
- Digital Calipers

Layout tools:

- Red and blue layout dye
- Scribes
- Layout kits
- Vernier Height Gage and Measuring Stone

Safety First!

Other tools:

- Hacksaws – Good for cutting perforated angle iron, certain cylindrical stock (e.g. – metal dowels, EFT, etc.), and general cutting
- Hand files – Often a good alternative to using the Bench Grinder or Belt and Disc Sander
- Tin snips – Good for cutting sheet metal
- Bending brake – Good for bending sheet metal

Tapping Holes and Using Dies

Often, your motivation for drilling a hole will be that you want to screw a fastener directly into it. To do that, you need to “tap” the hole – cut internal threads into to the wall of the hole to receive the external threads on the fastener. The process for tapping holes is:

1. BEFORE YOU DRILL YOUR HOLE, decide what type and size threads you want:
 - English (Unified National) or Metric?
 - Coarse or Fine?
 - ***It is strongly suggested that you select English, Coarse threads.*** The shop has the best and the most taps, drills, and fasteners of this type of screw.
2. Select the proper drill bit from the Tap and Drill Index
3. Drill the hole
4. Tap the hole

Technician Demonstration & Student Questions

The shop also contains the tools, dies, needed to cut external threads on a rod. However, since the need to do this arises so rarely and since threaded rod can be purchase quite cheaply, we will not be covering it in this training. Should your project require you to use dies, see the Technician, and he will provide you with one-on-one training.

Machine Shop Tell-Show-Do

Since time limitations do not allow us to fully examine all their possible uses and applications, we will examine each machine and power tool in the context of how students are most likely to use them in their Engineering course work at Trinity College.

Bench Grinder

Most Likely Student Uses

- Wire brush wheel – polishing and / or deburring a work piece
- Grinding wheel – making MINOR alterations to the shape a work piece

Bench Grinder Safety

1. **Never grind a soft material like aluminum.** Soft materials can coat the wheel:
 - A. Preventing the abrasive from working properly, and
 - B. ***Potentially leading to excessive heat build-up in the wheel causing it to explode.***
2. Never grind on the side of the wheel
3. Beware of heat build-up in the work piece when using the grinding wheel
4. Maintain proper orientation of the work piece to the wheel to prevent the work piece from being thrown
5. Do not use on Plexiglas, fiber glass, or printed circuit boards (PCB boards)

Technician Demonstration & Student Questions

Student Hands-On Experience

Concerning Band Saw Precision

Our band saws should not be considered “precision” cutting instruments. They produce good quality “rough” cuts that are more than adequate for most student projects. However, if you need your finished product to have highly precise dimensions, start by rough cutting your work piece with a band saw to a slightly larger size than you want your finished piece to be. Then, use the Bridgeport vertical milling machine to remove the remaining material.

Vertical Band Saw

Most Likely Student Uses

- Cutting thin pieces metal
- Making curved cuts
- Making angled cuts
- Cutting Plexiglas

Vertical Band Saw Safety

1. Do not use cutting fluid
2. Feed the work piece into the blade at a slow and steady pace
3. Keeping your fingers well away from the blade at all times
4. Keep the blade guard as low as possible
5. Brush the chips off the cutting table between cuts
6. Do not allow chips to accumulate on the floor around the band saw

Speed

This is a variable speed saw with four gears. The speed has been conservatively set in slowest gear. **Do not change the speed setting.**

Technician Demonstration & Student Questions

Student Hands-On Experience

Horizontal Band Saw

Most Likely Student Uses

- Cutting thick pieces of metal
- Making angled cuts

Horizontal Band Saw Safety

1. Always keep the band saw's power cord plugged into the overhead power cord reel
2. Secure the work piece tightly in the vise according to Figure 6

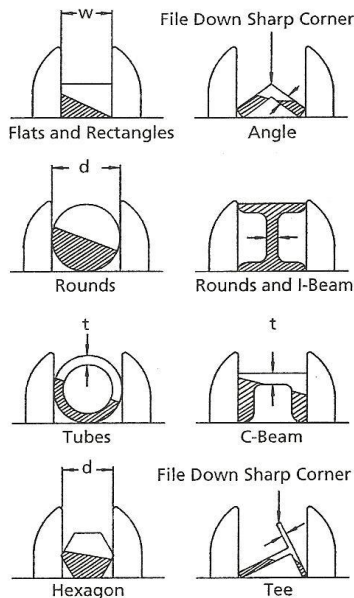

Figure 6 – Clamping Configurations and Thickness Average Calculation

Safety First!

3. Do NOT cut slotted or perforated angle iron with the horizontal band saw
4. **Maintain a dry, safe work environment at all times.** When wet cutting, dry the floor around the band saw between cuts.
5. If the blade jams in the work piece, lift up on the head of the saw to free the blade. If you cannot lift up the head, turn off the power to the saw and try again. If you still cannot lift up the head, ask the Department Technician for assistance.

Speed

This is a variable speed saw with three gears. The speed has been conservatively set in slowest gear. **Do not change the speed setting.**

Feed Pressure

This is a variable feed pressure saw. Feed pressure is the force with which the blade is applied to the work piece, and it is supplied by the weight of the head. The feed pressure has been conservatively set. **Do not change the feed pressure setting.**

Dry Cutting vs. Wet Cutting

The horizontal band saw is equipped with a coolant tank and pump. Different power switches control the saw blade and the coolant pump. That gives the saw operator the option of making dry cuts (without coolant) or wet cuts (with coolant).

Wet cutting provides the benefits of cooling the blade & work piece and lubricating the cut. However, the coolant that gets sprayed and dripped on the floor creates a slip-trip-and-fall hazard, and not all cuts require the use of coolant. Consequently, students are instructed to:

1. Cut aluminum dry (without coolant)
2. Cut steel and other very hard metals wet (with coolant)
3. **When wet cutting, maintain a safe and dry work environment at all times.**
 - Dry up any coolant on the floor between cuts.

Technician Demonstration & Student Questions

Dry Cutting Procedure

1. Raise the head to lift the blade just above the height of the work piece
2. Push the lever on the gold piping assembly down to the 9 o'clock position to freeze the head in place
3. Place the work piece in the vise and tighten it securely
4. Start the blade
5. Release the head by raising the lever on the gold pipe assembly to the 12 o'clock position
6. The saw will shut off automatically at the end of the cut

Wet Cutting Procedure

1. Check the coolant level in the coolant tank
 - Coolant should be just above the bottom of the tank's white plastic mesh strainer
 - If it is not, ask the Department Technician to add coolant before proceeding
2. Raise the head to lift the blade just above the height of the work piece
3. Push the lever on the gold piping assembly down to the 9 o'clock position to freeze the head in place
4. Place the work piece in the vise and tighten it securely
5. Start the blade
6. Start the coolant
 - The coolant pump is started and stopped by a toggle switch
 - Coolant flow is started, adjusted, and stopped by the red-handled ball valve at the end of the coolant tubing
 - Set coolant flow so that coolant slowly drips along the moving blade
 - This minimizes the amount of coolant that sprays / drips onto the floor
7. Release the head by raising the lever on the gold pipe assembly to the 12 o'clock position
8. The blade will stop automatically at the end of the cut
9. Stop the coolant:
 - Close the ball valve, then
 - Turn off the toggle switch
10. Dry up any coolant on the floor before making your next cut

Student Hands-On Experience

Belt and Disc Sander

Most Likely Student Uses

- Polishing and / or deburring a work piece
- Making MINOR alterations to the shape a work piece

Belt and Disc Sander Safety

1. Never operate a sander with a torn belt or loose disc
2. Do not use on Plexiglas, fiber glass, or printed circuit boards (PCB boards)
3. When using the Disc Sander, note the direction of rotation and place work piece accordingly

Technician Demonstration & Student Questions

Student Hands-On Experience

Drill Press

Most Likely Student Uses

Drilling holes

Drill Press Safety

1. Never leave the chuck wrench in the chuck
2. If you are not sure you can hold the work piece, clamp it or put it in a vice
3. Hold small work pieces in a vice

Technician Demonstration & Student Questions

Student Hands-On Experience

Corded Power Hand Drill

Most Likely Student Uses

Drilling holes in things that cannot fit or do not fit easily on the drill press table

Corded Power Hand Drill Safety

1. Make sure the work piece is firmly secured
2. Hold small work pieces in a vice

Technician Demonstration & Student Questions

Student Hands-On Experience

Bridgeport Vertical Milling Machine

Most Likely Student Uses

Machining work pieces to exact tolerances

Concepts to Remember when Using the Bridgeport

Speed = the rate at which the spindle turns in revolutions per minute (RPM).

Feed = the rate at which the work piece travels past the cutting tool in inches per minute (IPM).

Speed selection and Feed rate are determined by the tool you choose and the material you are machining.

Rules of Thumb to Remember

1. **As the diameter of the cutting tool increases, spindle speed decreases**
2. **As the hardness of the material being worked increases, spindle speed decreases**
 - Steel and iron (very hard materials) must be worked at speeds that are an order of magnitude slower than the speeds at which you would work aluminum (a soft material)
3. **When in doubt, work slower**
 - Working unnecessarily slowly will only result in the job taking longer, but working too fast can:
 - Damage or break the cutting tool
 - Inflict unnecessary wear and tear on the machine
 - Produce poor machining results (e.g. rough or scalloped finishes)

Appropriate Spindle Speeds for Student Projects

Cutting Tool Diameter	Approximate Appropriate Spindle Speeds When Milling:	
	Aluminum	Steel or Iron
3/4"	500 rpm	50 rpm
5/8"	600 rpm	60 rpm
1/2"	700 rpm	70 rpm
3/8"	850 rpm	85 rpm
1/4"	1,000 rpm	100 rpm

If you are uncertain about what spindle speed to use, how quickly to feed your piece past the mill, or anything else, ask the department Technician.

Bridgeport Vertical Milling Machine Safety

1. **The Bridgeport power switch controls BOTH the power and the direction of spindle rotation**
 - **Always use clockwise spindle rotation (otherwise, the cutting tool will not work)**
2. Do not leave the draw bar wrench on the draw bar
3. Make sure that the cutting tool and the work piece are tightly secured

Safety First!

Technician Demonstration & Student Questions

- Select a collet and end mill
- Secure the collet and end mill – **Don't forget to return the wrench to the nut**
- Secure the work piece
- Move the work piece to an appropriate starting position:
 - For slot cutting – no special considerations
 - For bottom cutting – no special considerations
 - For side cutting - **orient the work piece for conventional milling**
 - Conventional milling requires lower forces than climb milling. Consequently, it is easier on our old machine.
 - **Remember, the power switch controls both power and direction of spindle rotation**

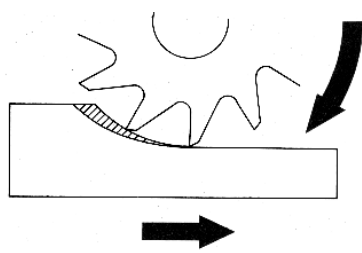

Conventional Milling

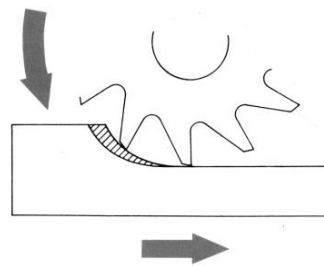

Climb Milling

- Lock the two planes along which you do not want motion to occur.
- Attach the Kool Mist system and position the nozzle optimally for chip removal, cooling, & lubrication
 - **Always use the Kool Mist cooling and lubricating system when milling**
 - **Be gentle with the valves**
- Determine the appropriate spindle speed from the table on the preceding page.
 - Changing the spindle **speed** – **done by students while the machine is running**
 - Vs.
 - Changing the spindle **gear** (Hi vs. Lo) – **done only by the dept. Technician while the machine is off**
- Using the digital display for the X and Y planes
- Using the dial gage for the Z plane
- Clean up procedure

Student Hands-On Experience

Closing Statement

Whenever you have a question on how to do something, ask the Technician, and always remember:

Safety First!

Engineering Department Machine Shop Student User Agreement

I understand that use of the Trinity College Engineering Department Machine Shop is a privilege, not a right. _____

I understand that the Engineering Department grants student access to its Machine Shop solely at its discretion. _____

If allowed access to the Machine Shop, I promise to obey the *Machine Shop Rules* at all times. _____

Machine Shop Rules

1. Safety glasses must be worn at all times.
2. Proper attire must be worn at all times. (Loose or dangling clothing, hair, or jewelry and open-toed shoes are not allowed.)
3. Students must complete orientation and safety training before they will be allowed in the Machine Shop
4. Students may not work alone in the Machine Shop.
5. Students may only use machines and power tools for which they have received training.
6. Absolutely, positively no horseplay is allowed in the Machine Shop.
7. Students have access to the Machine Shop Monday through Friday from 8:30am to 4:30pm.
8. Students may only use the Machine Shop to work on projects related to courses they are taking at Trinity College.
9. Students may not take tools out of the Machine Shop without the permission of the department Technician.
10. Students must clean up any mess they make and put away any tools they use before they leave the Machine Shop.
11. The compressed air hose may not be used to blow chips from a work piece or during the cleaning process.
12. Machine Shop doors must remain closed at all times.
13. Food and beverages are not allowed in the Machine Shop.
14. Students failing to comply with these rules will lose the privilege of using the Machine Shop.

I understand that if I violate *Machine Shop Rules* or behave in an unacceptable manner, the Engineering Department may revoke my access to the Machine Shop. _____

Student Name (please print legibly)

Student Signature

Date